

REVISION RECORD

REV.	DESCRIPTION	ECN No.	APPROVED	DATE

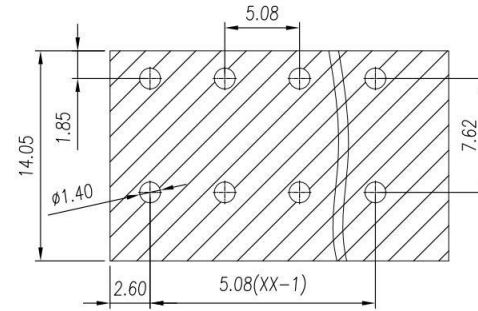

P.C.B. LAYOUT

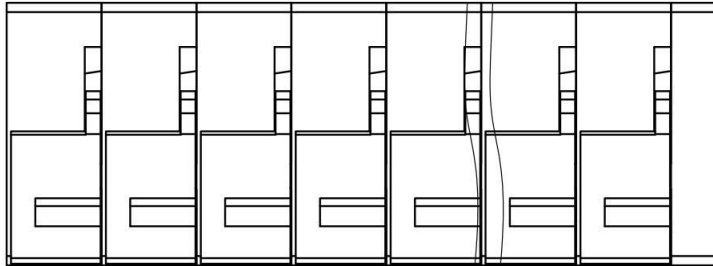
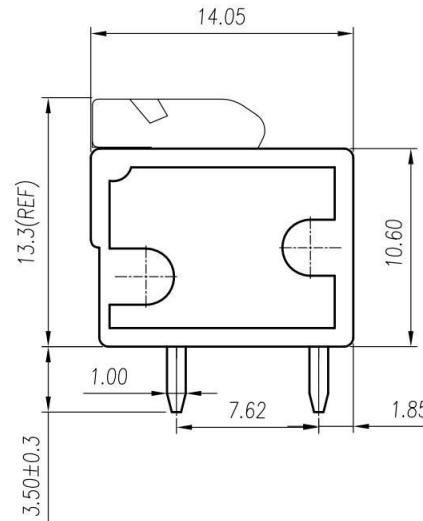
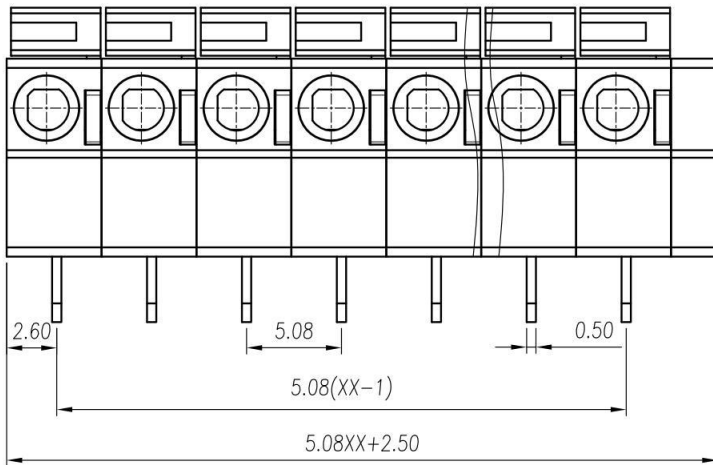

UL/CUL 技术参数		UL/CUL Technical Data		
等级	Use Group	B	C	D
额定电压	Rated Voltage [V]	300	-	300
额定电流	Rated Current [A]	10	-	10
接线范围	Wire Range	24-14		
单/多芯线	Solid/Stranded [AWG]			
耐电压	Withstanding Voltage	1600V/1Min		
IEC 技术参数		IEC60947-7-4		
过电压类别	Overvoltage Category	III	III	II
污染等级	Contamination Class	3	2	2
额定电压	Rated Voltage [V]	320	320	630
额定电流	Rated Current [A]	15	15	15
额定冲击电压	Impulse withstand voltage [KV]	4.0	4.0	4.0
导线截面积	Wire cross section	0.2-1.5		
硬质/柔性导线	Solid/flexible [mm <sup>2</sup> ]			
材料		Material		
绝缘材料	Insulation Material	PA66		
阻燃等级	Flammability	UL94V-0		
导体材料	Conductor Material	铜合金 Copper alloy		
导体表面镀层	Conductor Plating	镀锡 Sn Plated		
一般参数		Other Data		
间距	Pitch /极数 Poles [mm] / [P]	5.08 / 01-30		
剥线长度	Stripping Length [mm]	10-11		
螺丝	Screw/扭矩 Torque(Max) [N.m]	-		
工作温度	Operating temperature [°C]	-40~105		
焊锡温度	Soldering temperature [°C]	250 /5S		
引针尺寸	Pin Dimensions [mm]	1.0*0.5		
PCB板孔径	PCB Hole Diameter [mm]	Ø1.4		

linear dimension(Tolerances Standard GB/T 14486-2008)

variable range	to 6	over 6 to 10	over 10 to 30	over 30 to 60	over 60 to 100	over 100 to 160	over 160 to 10	over 10 to 100	over 100 to 100	
tolerance	±0.20	±0.30	±0.50	±0.70	±1.00	±1.30	±1.60	0.10	0.30	0.60

Contact:sales@nbkafeng.com

单位/UNITS	mm	尺寸/SIZE	A4	比例/SCALE	5:2	第三视角/THIRD ANGLE PROJECTION	版本/REV	V0
宁波咖峰电子有限公司 NINGBO KAFENG ELECTRONIC CO., LTD							名称/TITLE KF142R-5.08-XXP	